



DYNAMIC BRAKE CHOPPER BOARD

Datasheet



Version 1.1
Teleron
Copyright ©
2022



CONTENTS

- 1. Overview**
- 2. Technical Specifications**
- 3. Installing the Module and Setting the Threshold**
- 4. Connecting the Brake Chopper Board to the DC-**
 - 4.1 Suitable Cables**
 - 4.2 Cable Installation**
- 5. Multiple card option**
- 6. Failsafe Behavior**
- 7. Indicator Led**
- 8. Dimensions**

TABLE LIST

- | | |
|---------------------------|---|
| 1. Brake Chopper Features | 1 |
|---------------------------|---|

FIGURE LIST

1. Brake chopper Overview
2. Brake Chopper Connection Inputs
3. Brake Chopper Threshold Voltage Adjustment
4. Brake Chopper DC Bus Connection Inputs
5. Multi-Drive Wiring Diagram
6. Brake chopper Indicator LED
7. Brake Chopper Physical Dimensions

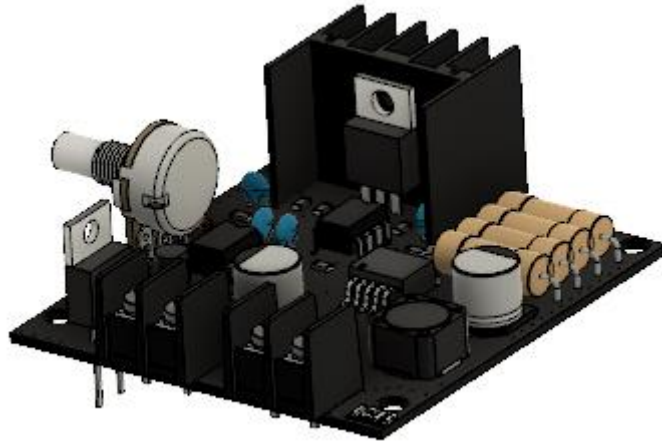

Figure 1: Brake Chopper Overview

1. Overview

Dynamic Brake chopper board, brake chopper 48 VDC 200 Watt is a brake chopper (also called shunt or regen board) that can be used with drivers with suitable inputs. It is used to consume excess energy that may occur in the DC bus while slowing the electric motor load.

Brake Chopper 48V 200W is capable of delivering up to 200W of continuous power if adequate cooling is provided.

When the motor is used to actively slow a load, electrical power will be regenerated. If the drives are supplied with a standard power supply (without recovery function), such regenerative duty points will cause an overvoltage in the DC circuit and therefore the drive or power supply will be turned off.

To prevent this from happening, a shunt circuit is required to burn this recovered energy.

2. Technical Specifications

Table 1: Brake Chopper Features

General features	
Standard Bus Voltage	48 VDC
Activation threshold voltage V_{th}^*	It can be adjusted between 50-57 V by the user.
Maximum Voltaj	57V
Rated continuous power	200 W, depending on cooling condition and duty cycle
Max. Power	200 Watt
Peak power application period ***	500 μ s
Ambient temperature for power ratings	Room temperature (20 °C)
Maximum system temperature ***	< 75 °C

***This voltage defines the voltage at which the first shunt starts to become active.**

*****The Brake Chopper can emit up to 200 W for periods of 500 μ s. Please ensure that the Brake chopper is mounted on a suitable surface with a large enough volume to dissipate the heat generated.**

If the voltage level is above the Threshold Voltage, the shunts of the board will be activated.

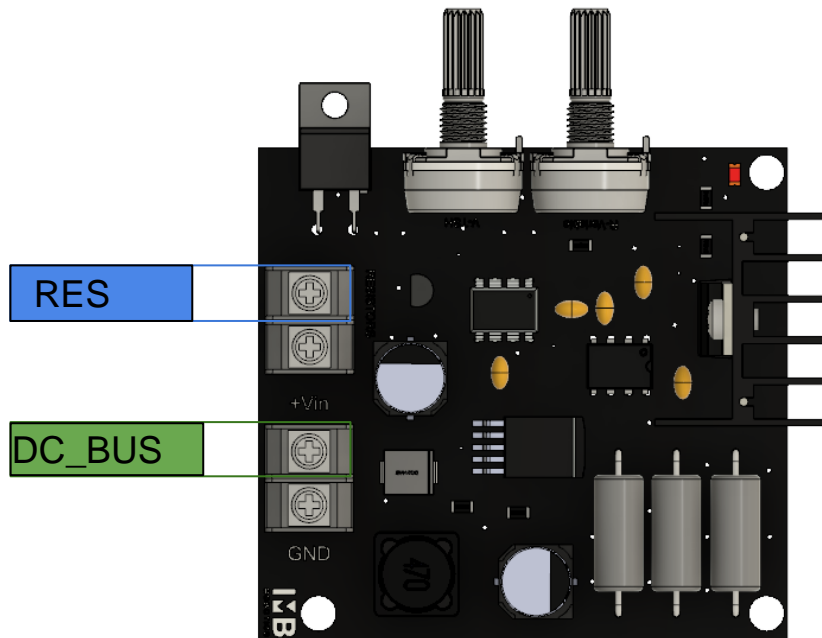

Figure 2: Brake Chopper Connection Inputs

3.Installing the module and setting the threshold voltage

Install the resistor board connected to the brake chopper circuit in a suitable location with good cooling. Make sure the bottom is connected to a thermally conductive metal structure.

!!! A suitable thermal conductivity is essential to ensure optimum performance. It is recommended to use silicone paste or thermal pad.

Connect the brake chopper cables to the DC bus. The circuit must be connected in parallel with the driver boards. You can use the voltage adjustment pot on the top of the board to adjust the threshold voltage: 50 V, - 57 VDC

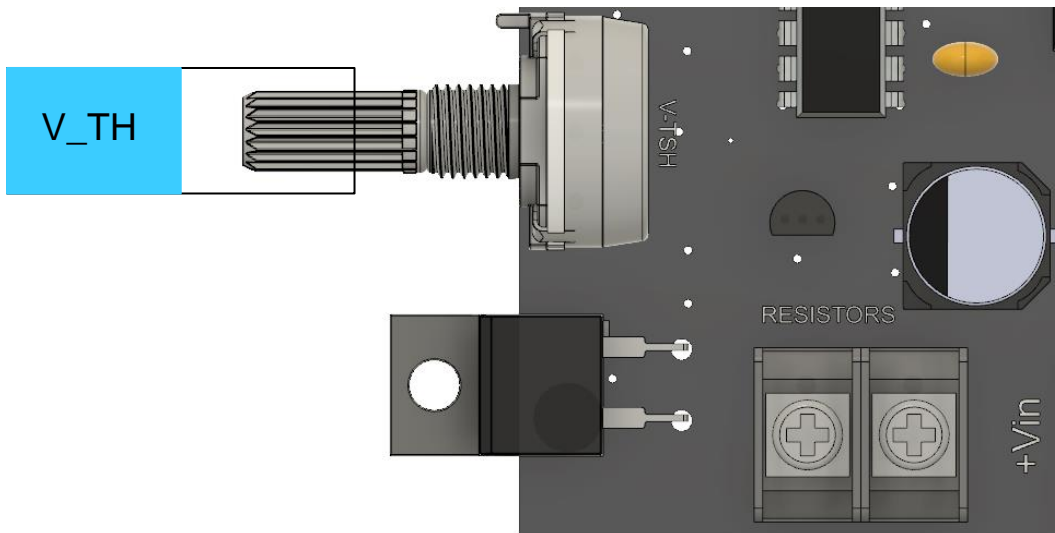

Figure 3: Brake Chopper Threshold Voltage Adjustment

4. Connecting the Brake Chopper Board to DC-BUS

4.1 Suitable Cables

- V_IN, Red Core Cable , 14AWG
- GND, Black Core Cable, 14AWG

!! Use suitable cable lugs for secure connection.

4.2 Cable Assembly

Before connecting the wires, please pay attention to the correct polarity indicated by +/-

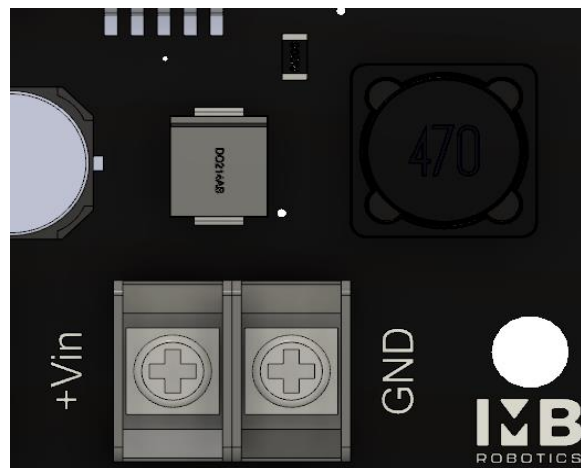

Figure 4: Brake Chopper DC Bus Connection Inputs

5. Multi card option

Total shunt power required in a robotic system, robot inertia, payload, number of axes, size and type of motors, trajectory, controller settings, braking and fast stop strategies etc. It depends on many factors, including There is no universal rule to indicate how many IMB Brake boards are required for a given number of motors. Developers should calculate the regenerative forces and energies in the respective load cycle of their robot or measure these values in experiments.

Some practical tips for getting started:

If decelerations and loads are moderate, one brake chopper card can handle the renewed energy of several Drives. In many real world applications this is already sufficient, so one IMB Brake card per robot is usually sufficient.

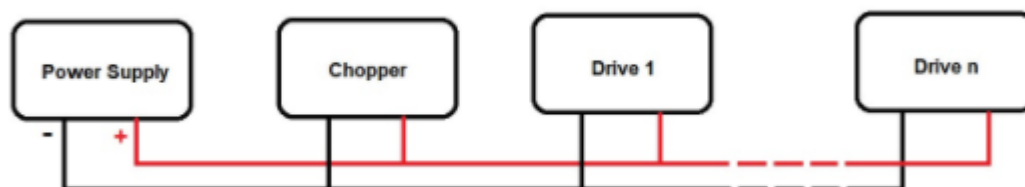

Figure 5: Multi-Drive Wiring Diagram

Attention!!

A small size chopper system can also lead to dangerous situations when the robot cannot slow down properly.

6. Failsafe Behavior

If the power on the DC bus exceeds Peak Power or the shunts reach their temperature limits, the shunt is disabled to prevent burnout of the resistors. In this case, the DC bus will act as if no shunt is installed. Thus the DC bus voltage will continue to increase until the overvoltage protection of the Drive is triggered.

7.LED

When the red indicator LED on the card is active, it indicates that the brake chopper circuit is active.

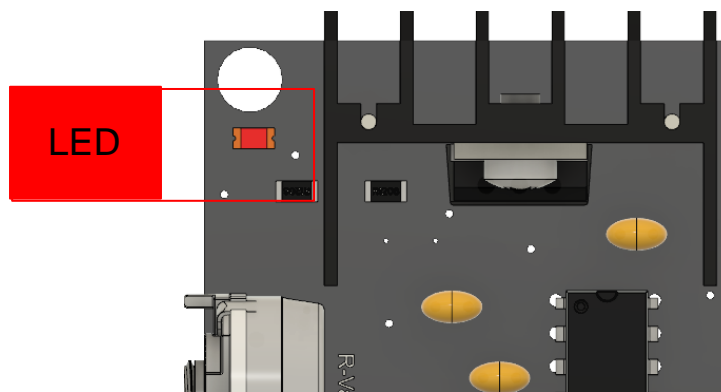

Figure 6: Brake chopper Indicator LED

8. Dimensions

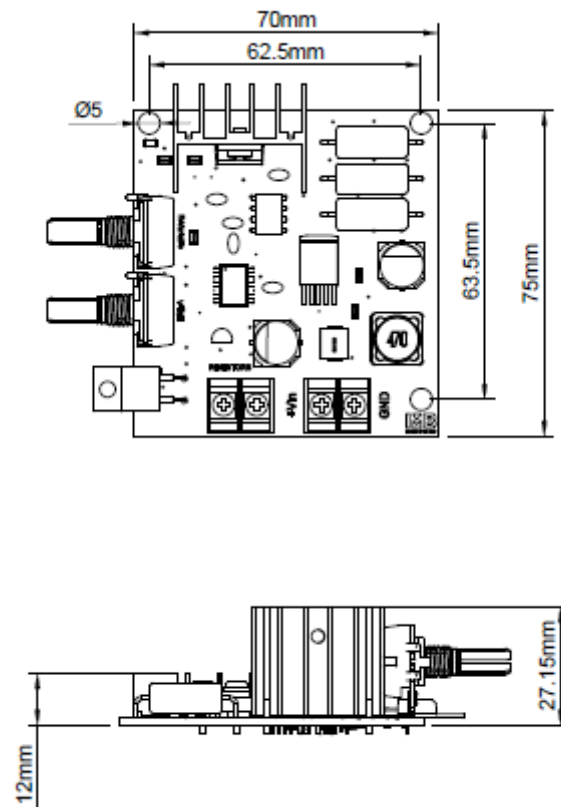

Figure 7: Physical Dimensions of Brake Chopper